

TECHNICAL GUIDE

TOUGH GUN ThruArm™ G2 Series Robotic MIG Guns for FANUC ROBOTS 100iC, 100iC-6L, 120iC, 120iC-10L

- **INSTALLATION**
- **MAINTENANCE**
- **TECHNICAL DATA**
- **OPTIONS**
- **EXPLODED VIEW & PARTS LIST**
- **ORDERING INFORMATION**

*Certified ISO 9001 : 2008
Please read instructions prior to use.
Save this manual for future reference*

TABLE OF CONTENTS

THANK YOU	2
GENERAL SAFETY INFORMATION	3
WARRANTY	3
1.0 – COMPLETE ASSEMBLY OVERVIEW	4
2.0 – INSTALLATION	4
STEP #1 - POSITIONING THE ROBOT	4
STEP #2 - INSTALLING INSULATING DISC.....	5
STEP #3 - INSTALLING ALUMINUM SPACER.....	5
STEP #4 - INSTALLING LSR UNICABLE.....	5
STEP #5 - INSTALLING FRONT HOUSING.....	6
STEP #6 - INSTALLING FASTENER COVER.....	7
STEP #7 - INSTALLING GOOSENECK / GOOSENECK REPLACEMENT	7
STEP #8 - INSTALLING POWER PIN TO THE LSR UNICABLE.....	8
STEP #9 - INSTALLING QUICK LOAD™ LINER	8
STEP #10 - INSTALLING CONSUMABLES	9
STEP #11 - INSTALLING GUN TO FEEDER	9
3.0 – MAINTENANCE	10
3.1 REPLACEMENT OF EURO CONNECTION.....	10
3.2 REPLACEMENT OF QUICK LOAD™ LINER	11
4.0 – TECHNICAL DATA	12
4.1 GUN CONFIGURATIONS.....	12
4.2 CENTER OF MASS.....	12
4.3 AMPERAGE RATINGS*	13
5.0 – OPTIONS	13
5.1 WIRE BRAKE REMOVAL AND INSTALLATION.....	13
6.0 – EXPLODED VIEW AND PARTS LIST	14
6.1 AIR-COOLED MODELS.....	14
6.2 TOUGH GUN I.C.E.™ MODELS.....	15
7.0 – ORDERING INFORMATION	16

THANK YOU

...for selecting a Tregaskiss TOUGH GUN™ ThruArm G2 Series Robotic MIG Gun. Manufacturing operations demand extremely dependable robotic equipment. With this in mind, the TOUGH GUN™ MIG Gun was designed and engineered to be a reliable tool to support high production within a robotic cell. Your TOUGH GUN MIG Gun is completely assembled and ready to weld, and has undergone numerous quality checks to ensure high performance.

The instructions and illustrations in this technical guide make it easy for you to maintain your TOUGH GUN MIG Gun. **Please read, understand, and follow all safety procedures.** Keep this Technical Guide booklet as a handy reference when ordering complete guns, parts and special options. **For technical support and special applications, please call the Tregaskiss Technical Service Department at 1-877-737-3111 or fax 1-877-737-2111.** Our trained technicians are available between 8:30 AM and 5:00 PM EST, and will answer your application or repair questions.

Tregaskiss employees build TOUGH GUN MIG Guns for the world's welding professionals. We are always striving to improve our products and services, and would appreciate receiving your suggestions or comments. Please contact us immediately if you experience any safety or operating problems.

GENERAL SAFETY INFORMATION

Before installation or operation of TOUGH GUN MIG Guns, please read the following safety precautions.

1. Do not touch live electrical parts. The following should be checked to prevent electrical shock:
 - Faulty or damaged equipment is repaired or replaced.
 - Equipment is off when not in use.
2. Ensure that all safety devices, guards, shields or barriers are properly in place and connected correctly before allowing operation of the equipment.
3. CSA Standard W117.2 CODE FOR SAFETY IN WELDING AND CUTTING obtainable from the Canadian Standards Association, Standards Sales, 178 Rexdale Boulevard, Rexdale, Ontario, Canada M9W 1R3.

ANSI Standard Z49.1 CODE FOR SAFETY IN WELDING AND CUTTING obtainable from the American National Standards Institute, 1430 Broadway, New York, NY 10018.

CALIFORNIA PROPOSITION 65 WARNING

This product, when used for welding or cutting, produces fumes or gases which contain chemicals known to the State of California to cause birth defects and, in some cases, cancer.

This product contains chemicals, including lead, known to the State of California to cause cancer, and birth defects or other reproductive harm. *Wash hands after use.*

(California Health & Safety Code Section 25249.5 at seq.)



WARRANTY

Product is warranted to be free from defects in material and workmanship for the period specified below after the sale by an authorized Buyer. Should there be a defect please refer to our Return Merchandise Policy.

PRODUCT	WARRANTY PERIOD
TOUGH GUN™ MIG Guns and Components	180 days
TGX™ Chassis and TGX™ Ready To Weld MIG Guns	90 days
TOUGH GUN™ Reamer	1 year
TOUGH GARD™ Spatter Cleaner	1 year
TOUGH GUN™ Robotic Peripherals (Clutch, Sprayer, Wire Cutter, Clutch Disc, Mounting Arms)	1 year
Low-Stress Robotic Unicables (LSR Unicables)	2 years

Tregaskiss reserves the right to repair, replace or refund the purchase price of non-conforming product. Product found not defective will be returned to the Buyer after notification by Customer Service.

Tregaskiss makes no other warranty of any kind, expressed or implied, including, but not limited to the warranties of merchantability or fitness for any purpose. Tregaskiss shall not be liable under any circumstances to Buyer, or to any person who shall purchase from Buyer, for damages of any kind including, but not limited to any, direct, indirect incidental or consequential damages or loss of production or loss of profits resulting from any cause whatsoever, including, but not limited to, any delay, act, error or omission of Tregaskiss.

Genuine Tregaskiss parts must be used for safety and performance reasons or the warranty becomes invalid. Warranty shall not apply if accident, abuse, or misuse damages a product, or if a product is modified in any way except by authorized Tregaskiss personnel.

1.0 – COMPLETE ASSEMBLY OVERVIEW

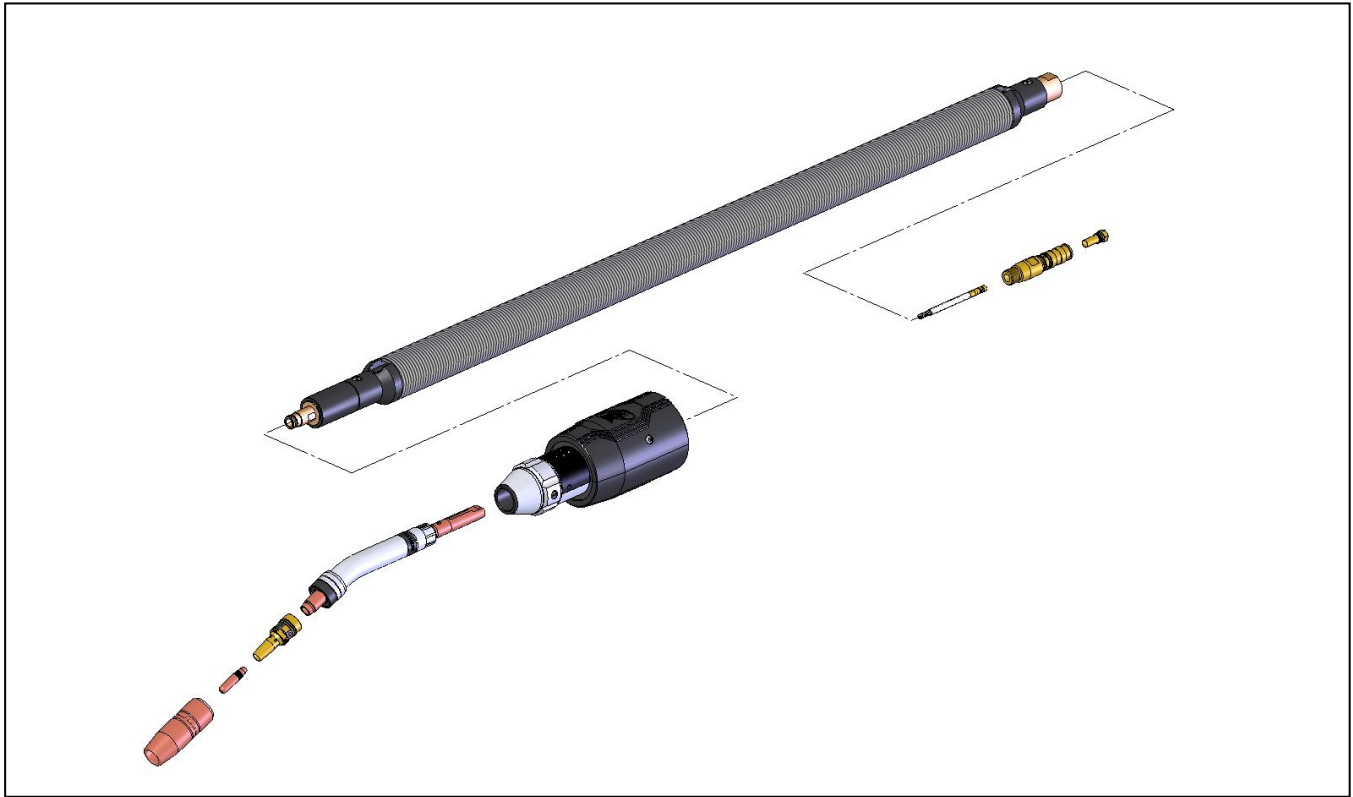

For part numbers, see **Section 6.0 – EXPLODED VIEW AND PARTS LIST**.

2.0 – INSTALLATION

STEP #1 - POSITIONING THE ROBOT

- Position the robot with the wrist and top axis 180° parallel to each other (as shown) to properly complete the gun installation.

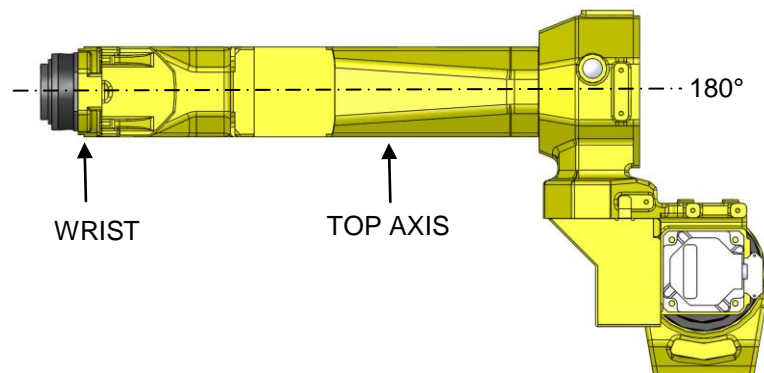

STEP #2 - INSTALLING INSULATING DISC

- Begin by installing insulating disc, being sure to align dowel pin with associated hole on robot mounting face. **NOTE:** dowel will be pressed into disc prior to shipping.
- Attach insulating disc using the provided M4X.7X12 cap screws (X4). Torque to 25 in.-lbs./2.8 Nm.

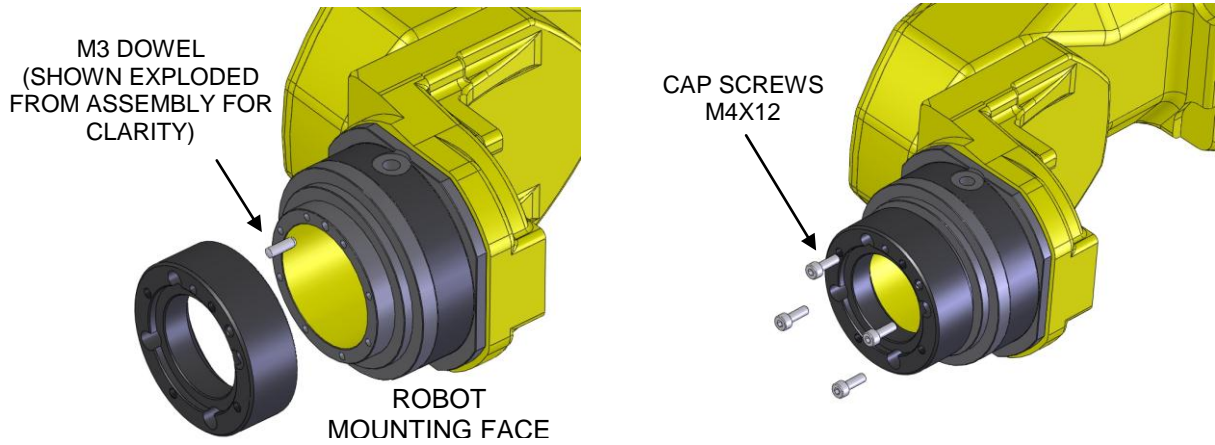

STEP #3 - INSTALLING ALUMINUM SPACER

- Next, install aluminum spacer, again, aligning dowel pin to dowel pin hole on robot face. **NOTE:** Dowel will be pressed into aluminum prior to shipping.
- Install provided M5X.8X25 cap screws (X4). Torque to 25 in.-lbs./2.8 Nm.

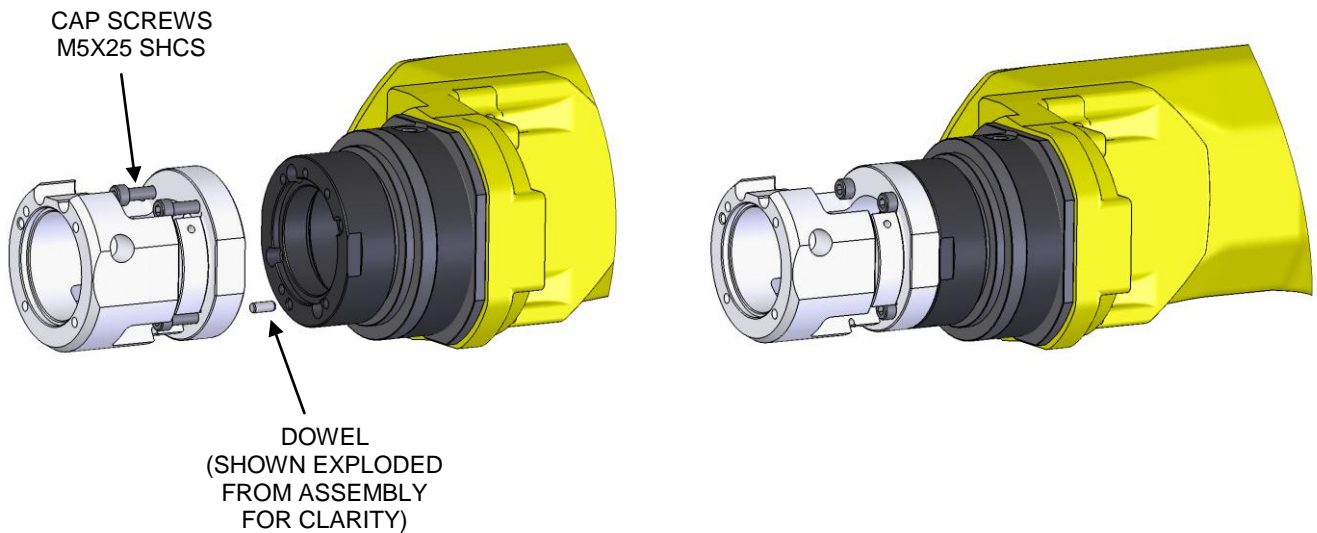

STEP #4 - INSTALLING LSR UNICABLE

- Feed the cable by bending it in a “U” shape. Insert the rear portion through the robot arm shroud and the front portion through the aluminum spacer.

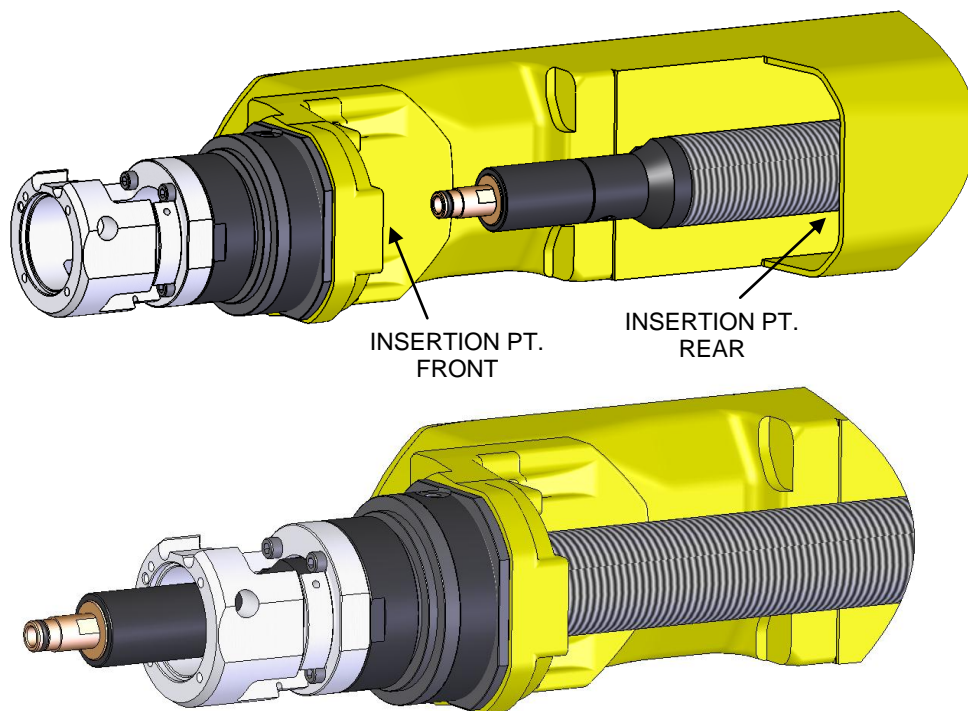

STEP #5 - INSTALLING FRONT HOUSING

- Firmly grasp the unicable at the indicated location. Next bring the front end housing toward the unicable and insert fully onto the pin at the end of the unicable. Force the two components together until contact surfaces 1 and 2 are touching firmly.

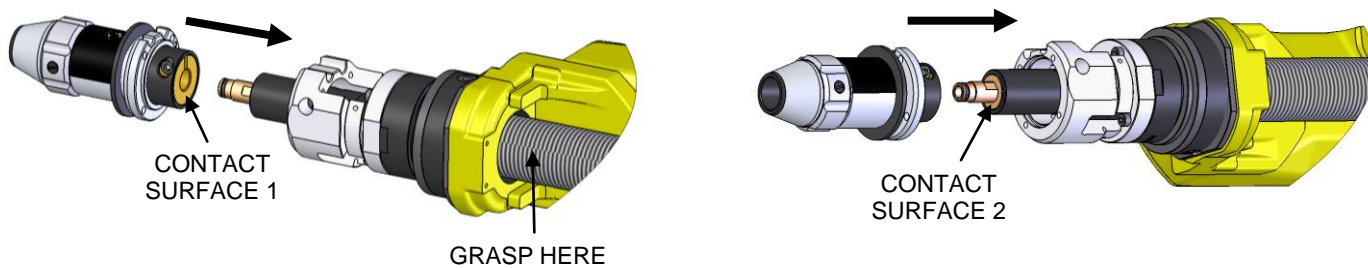

- Fasten ThruArm Solid Mount to LSR Unicable by tightening front housing cap screw M6X1X12. Torque to 80 in.-lbs. / 9 Nm.

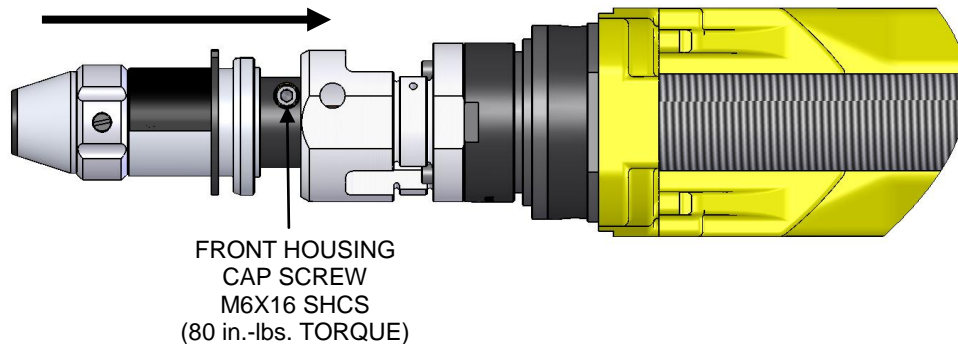

- Next, fasten front housing and aluminum spacer together using M5X.8X16 cap screws (X4). Torque to 50 in.-lbs. / 5.5 Nm.

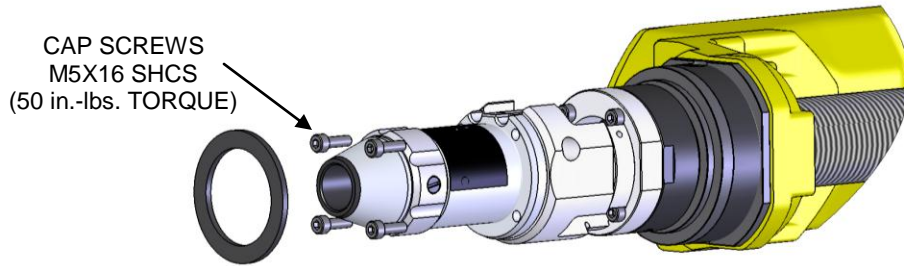

STEP #6 - INSTALLING FASTENER COVER

- Slide fastener cover up and into place and then attach using flat head cap screws (X2). Torque to 12 in.-lbs./1.4Nm.

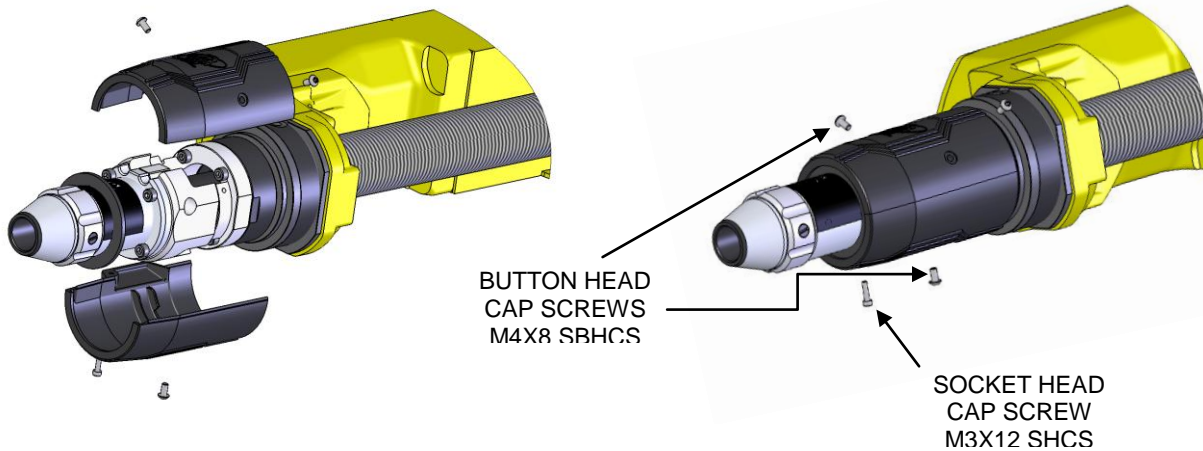

STEP #7 - INSTALLING GOOSENECK / GOOSENECK REPLACEMENT

IMPORTANT! Remove consumables (i.e. retaining head, nozzle and contact tip) before installing gooseneck. Failure to do so will result in improper installation.

- Twist the hand nut clockwise to UNLOCK. **IMPORTANT:** To prevent damage to the gooseneck, ensure that the hand nut is always in the UNLOCKED position when inserting a gooseneck.
- Insert the gooseneck into the connector housing. **IMPORTANT:** The gooseneck is fully inserted only when the gooseneck bottoms out and the insertion depth guide (INSERT TO HERE) on the gooseneck meets up with the connector housing.
- Release the hand nut allowing it to return to the LOCKED position. **IMPORTANT:** Do not release the hand nut unless the gooseneck has been fully inserted or damage to the gooseneck may result.

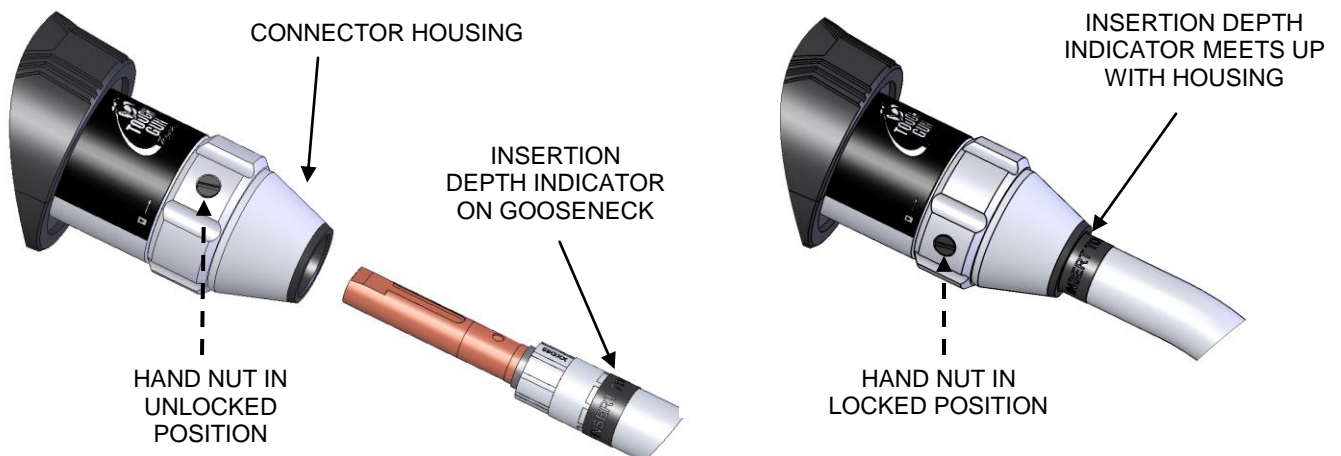

STEP #8 - INSTALLING POWER PIN TO THE LSR UNICABLE

Option #1 of 2: Power Pins

- Install power pin onto the LSR Uncable.
NOTE: Power pins incorporate a taper to seat and lock the pin to the rear handle block. Make sure the power pin is tightened in the block with a wrench to insure the pin is secure and will not come loose.
 - Thread power pin into the adapter of the LSR Uncable.
 - Tighten the power pin into the rear block using a 1" (25 mm) wrench on the rear block and a 5/8" (16 mm) or 3/4" (19 mm) wrench on the power pin.
 - Torque to 18 ft.-lbs. / 24.4 Nm.

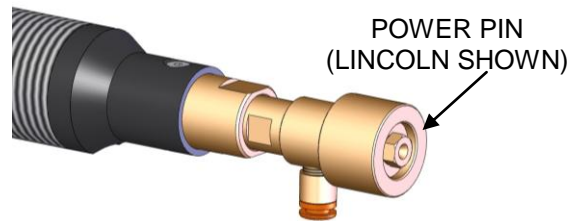

Option #2 of 2: Euro Connection

- The Euro connection comes factory installed. No installation required.



STEP #9 - INSTALLING QUICK LOAD™ LINER

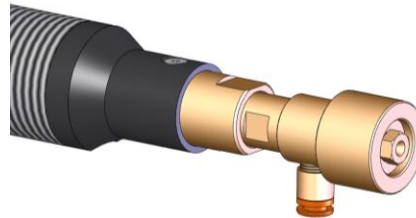
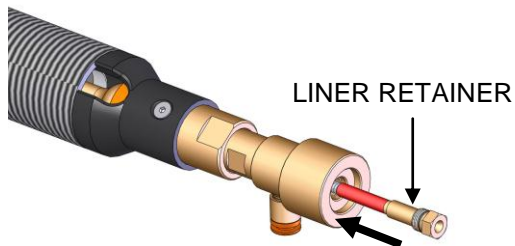

- Insert brass end of the liner into the liner retainer until firmly seated.
- Insert non-brass end of QUICK LOAD™ Liner into back of the gun and push through until it emerges from the front of the gun and the liner retainer makes contact with the power pin.
- Thread the QUICK LOAD Liner retainer (#415-26) into the power pin. Torque to 30 in.-lbs. (3.5 Nm).
- Push liner back into front of gun and hold in place.
- Trim liner to a 5/8" (16 mm) stick out.
- Remove any burrs that may obstruct wire feed.

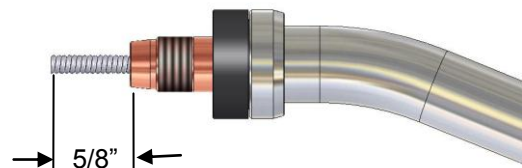

STEP #10 - INSTALLING CONSUMABLES

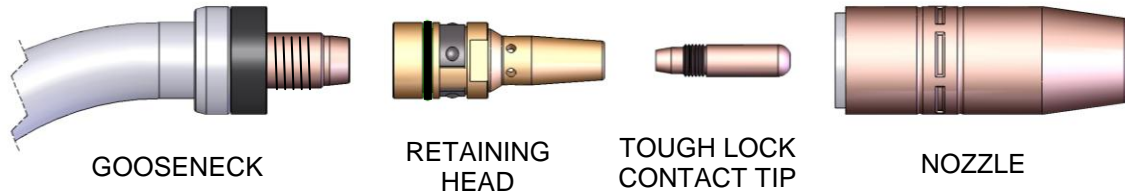

Retaining Head

- Thread the retaining head onto the gooseneck.
- Use a 5/8" wrench and tighten to 80 in.-lbs. (or 9 Nm).

Contact Tip

- Thread the contact tip into the retaining head.
- Torque to 30 in.-lbs. (3.5 Nm).

Nozzle

- Push the slip-on TOUGH GUN Nozzle over the retaining head/contact tip combo until the nozzle is fully seated.
- **IMPORTANT:** Be sure all consumables are tightened properly and fully seated before welding to prevent overheating.

STEP #11 - INSTALLING GUN TO FEEDER

- Ensure that the bolts clamping the feeder to the bracket on the robot are loosened.
- Insert power pin on the rear of the unicable into the feeder.
- Slide the feeder towards the front of the robot. This will create a necessary curve in the cable to allow for proper operation. **REMINDER:** The robot's top axis must be at 180 degrees during installation.
- The feeder should be pressed forward far enough that the centerline of the unicable should bow approximately 1.5" at its highest point, from a straight through position (see diagram).
- Tighten feeder bracket bolts to manufacturer's recommendations to ensure that feeder remains in the proper position.

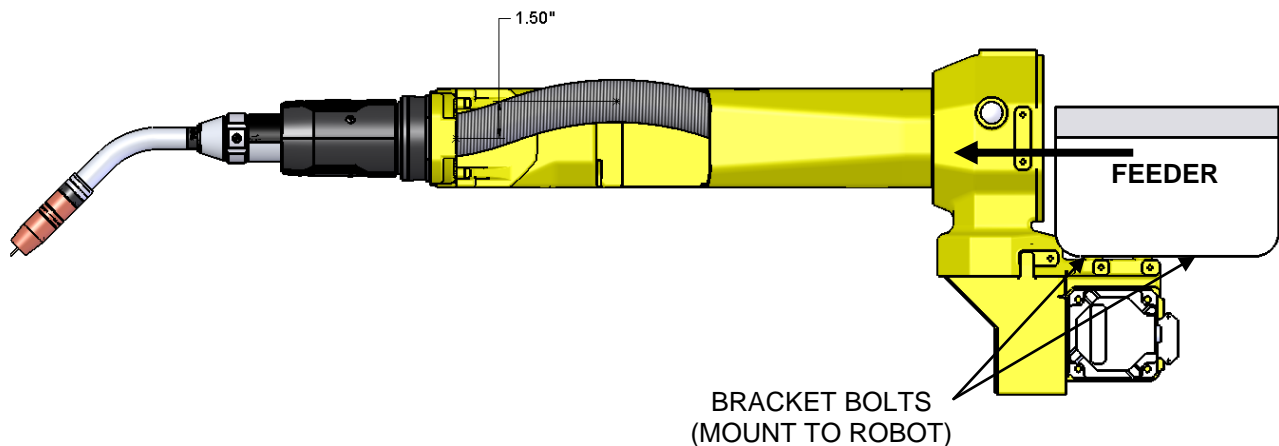

3.0 – MAINTENANCE

3.1 REPLACEMENT OF EURO CONNECTION

- Remove M5 x 6 mm countersunk fasteners.
- Slide the hand nut over the Euro power pin body.
- Torque the power pin body to the threaded end of the unicable at 18 ft.-lbs. (24 Nm) using 7/8" & 13/16" wrenches. You may have to pull back on the outer conduit to achieve this.
- Once the power pin body is in place, pull the conduit down over it. Rotate the conduit so that the holes on the power pin line up with the holes on the plastic end of the conduit.
- Insert the two M5 x 6mm countersunk screws and torque to 12 in.-lbs. (1.35 Nm). You may have to rotate the hand nut to access the holes.

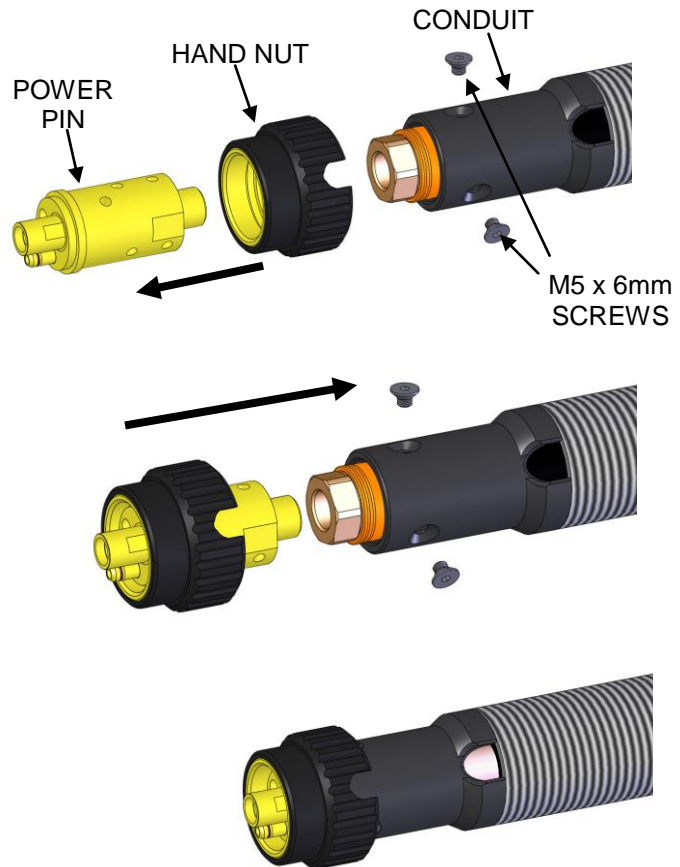

3.2 REPLACEMENT OF QUICK LOAD™ LINER

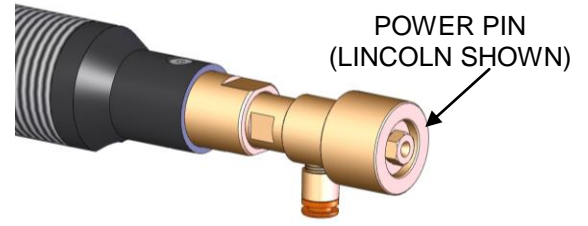
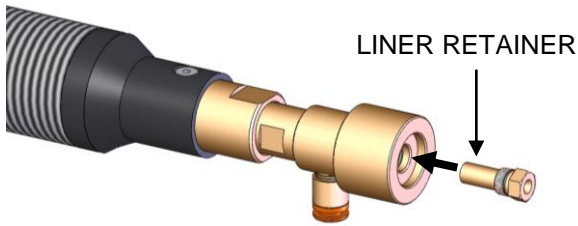

- **NOTE: One liner retainer can last for multiple liner replacements. Therefore this step is not required for every liner change.** Remove the QUICK LOAD™ Liner retainer (#415-26) from the power pin and thread in new one. Torque to 30 in.-lbs. (3.5 Nm).
- Remove consumables (nozzle, contact tip, retaining head).
- Remove existing QUICK LOAD Liner.
- Insert new QUICK LOAD Liner through gooseneck using the wire as a guide. Short strokes will prevent the wire from kinking.
- Once the liner stops feeding, give it an extra push to ensure it is inserted completely.
- Trim liner to a 5/8" (16 mm) stick out.
- Remove any burrs that may obstruct wire feed.
- Reinstall consumables.

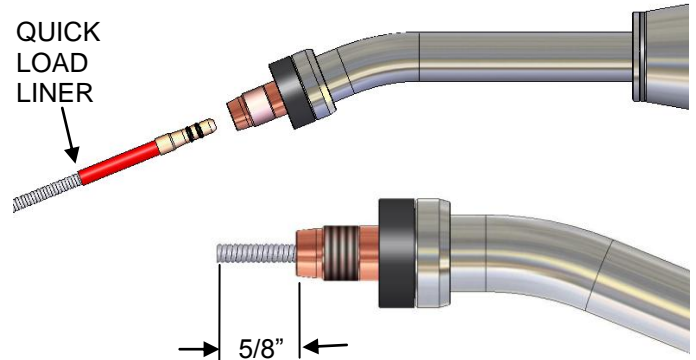

4.0 – TECHNICAL DATA

4.1 GUN CONFIGURATIONS

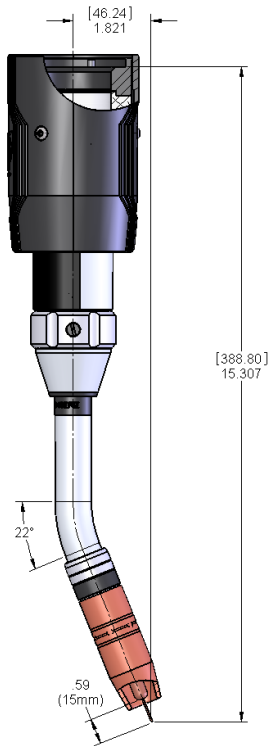

22° Gooseneck, Part # 59G22 – 0.59" (15 mm) CTWD

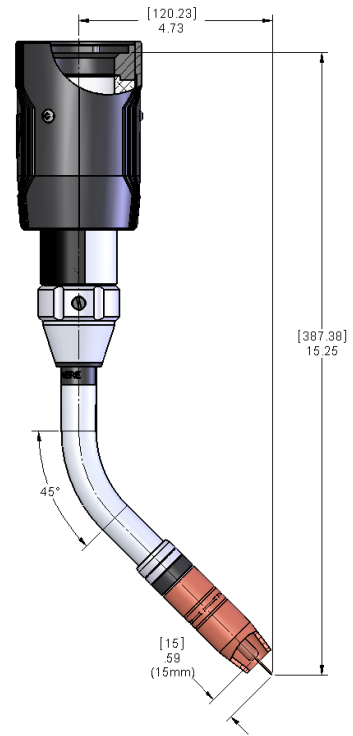

45° Gooseneck, Part # 59G45L – 0.59" (15 mm) CTWD

4.2 CENTER OF MASS

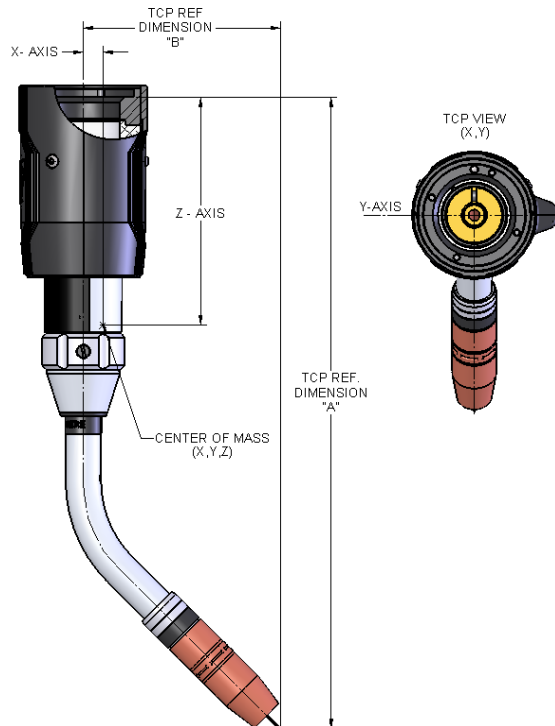

	22° NECK	45° NECK
X	0.16" (4.08 mm)	0.47" (12.04 mm)
Y	0	0
Z	5.42" (137.66 mm)	5.66" (143.80 mm)
WEIGHT	3.43 LBS (1.56 kg)	3.37 LBS (1.52 kg)
TCP REF. DIM. "A"***	15.31" (388.80 mm)	15.25" (387.38 mm)
TCP REF. DIM. "B"***	1.82" (46.24 mm)	4.73" (120.23 mm)

***WITH 0.59" (15 mm) WIRE STICKOUT

4.3 AMPERAGE RATINGS*

GUN MODEL	60% DUTY CYCLE - MIXED GASES OR 100% DUTY CYCLE - CO ₂
THRUARM SERIES – AIR-COOLED	500 amp

*Ratings are based on tests that comply with IEC 60974-7 standards.

5.0 – OPTIONS

5.1 WIRE BRAKE REMOVAL AND INSTALLATION

NOTE: Wire brake can only be used if gun was originally ordered with Wire Brake option. The QUICK LOAD™ Liner is not offered for Wire Brake gun assemblies.

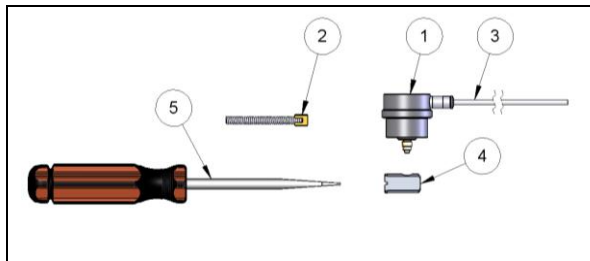

ITEM	PART #	DESCRIPTION
1	599	PUSHING PIN
2	495-18-35	JUMP LINER FOR ≤ 0.045 "
	495-18-116	JUMP LINER FOR ≥ 0.052 "
3	499-9-15	AIR LINE 15'
4	598G2	WIRE GUIDE FOR ≤ 0.045 "
	598G2-116	WIRE GUIDE FOR ≥ 0.052 "
5		FLAT HEAD SCREW DRIVER

1. Unthread the pushing unit (1) and remove the wire guide (4) (See Fig. 1). **NOTE:** Gun housing is different from the illustration shown.
2. Using the flat head screw driver (5), insert the wire guide (4) (flats parallel with housing key) into position within the housing (See Fig. 2). Rotate wire guide (4) to align hole with pushing unit pin (1), thread-in the pushing unit (1) (See Fig. 3). **NOTE:** Gun housing is different from the illustration shown.

Fig. 1

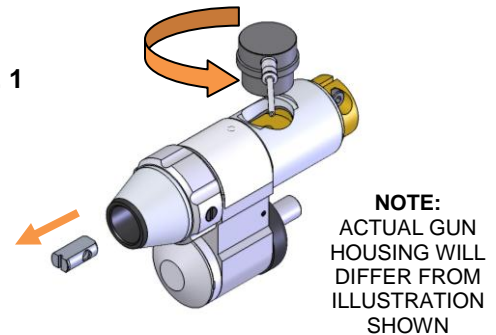

Fig. 2

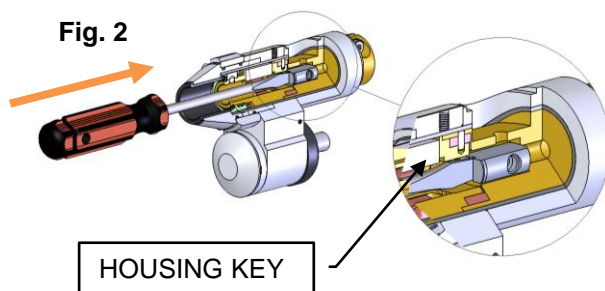
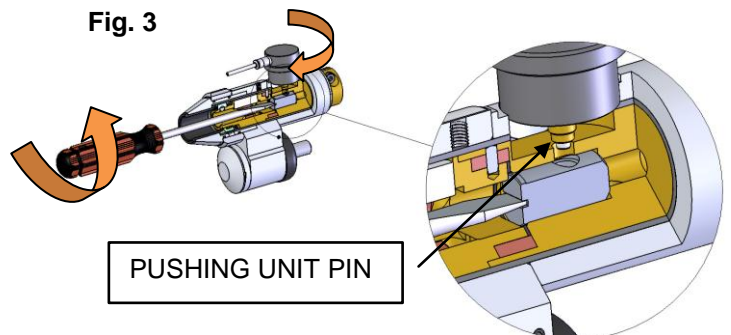

Fig. 3



IMPORTANT:

For the Wire Brake to work properly, make sure the pushing unit bottoms-out in the housing/connector.

6.0 – EXPLODED VIEW AND PARTS LIST

6.1 AIR-COOLED MODELS

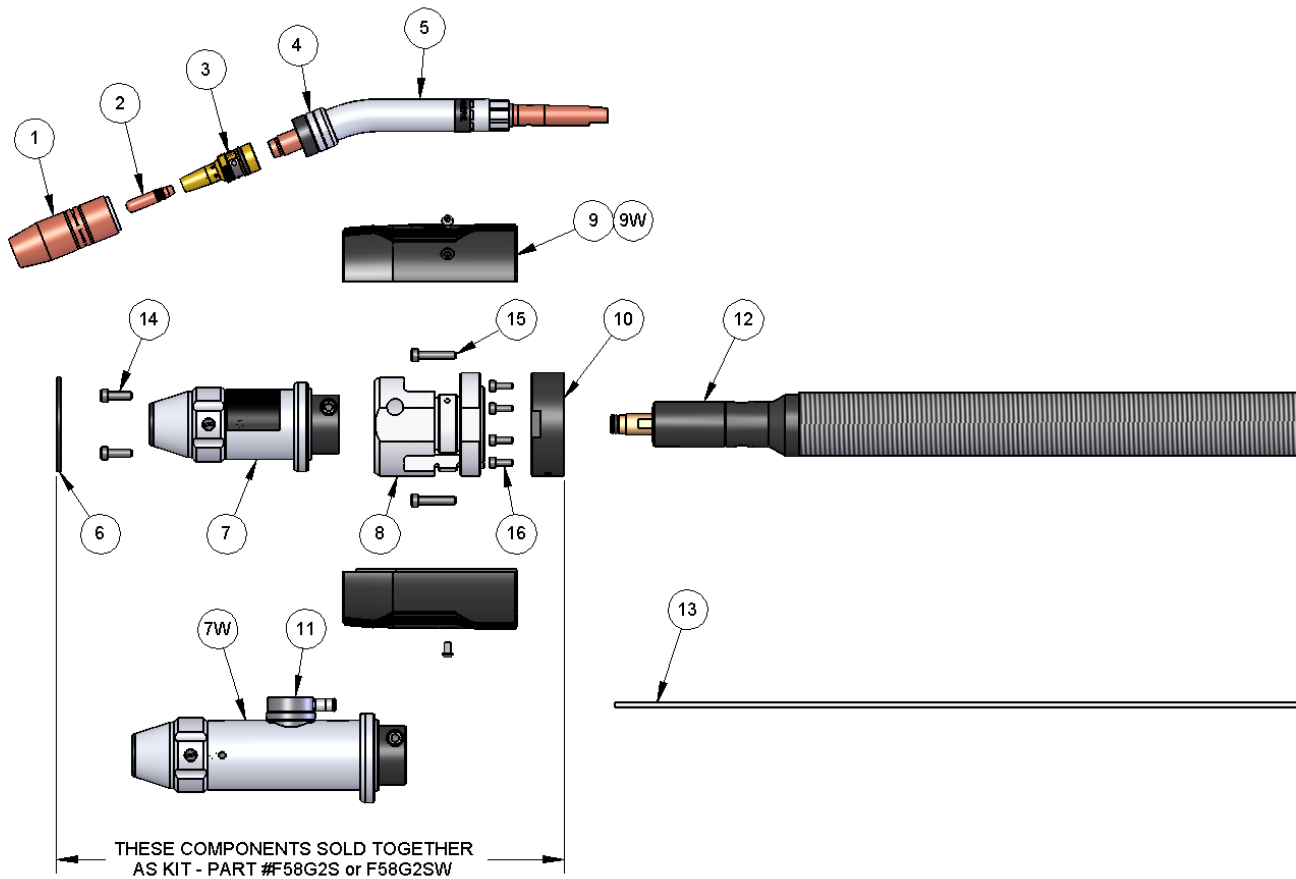

PART #	DESCRIPTION
1	401-X-XX NOZZLE
2	403-XX-XX TOUGH LOCK TIP
3	404-XX RETAINING HEAD
4	402-11 GOOSENECK INSULATOR
5	59G22 GOOSENECK 22 DEGREE
	59G22L GOOSENECK MEDIUM LENGTH 22 DEGREE
	59G22L1 GOOSENECK LONGER LENGTH 22 DEGREE
	59G35 GOOSENECK 35 DEGREE
	59G45 GOOSENECK 45 DEGREE
	59G45L GOOSENECK STANDARD 45 DEGREE
	59G45L1 GOOSENECK MEDIUM LENGTH 45 DEGREE
	59G45L2 GOOSENECK LONGER LENGTH 45 DEGREE
6	580-400-4 THRUARM G2 RUBBER WASHER
7	580-400 THRUARM G2 CONNECTOR

PART #	DESCRIPTION
7W	580-400W THRUARM G2 CONNECTOR WB
8	560-501-10 W/C SPACER ASSEMBLY
9	580-400-7 FANUC OUTER COVER
9W	580-400-5 FANUC OUTER COVER WB
10	560-501-11 INSULATING DISC
11	599 WIRE BRAKE UNIT
12	58SF005 LSR UNICABLE FOR 100iC
	58SF006 LSR UNICABLE FOR 120iC
	58SF007 LSR UNICABLE FOR 100iC-6L
	58SF008 LSR UNICABLE FOR 120iC-10L
13	499-9-10 WIRE BRAKE LINE
	M5X.8X16mm LG SHCS
	M5X.8X25mm LG SHCS
	M4X.7X12mm LG SHCS

6.2 TOUGH GUN I.C.E.™ MODELS

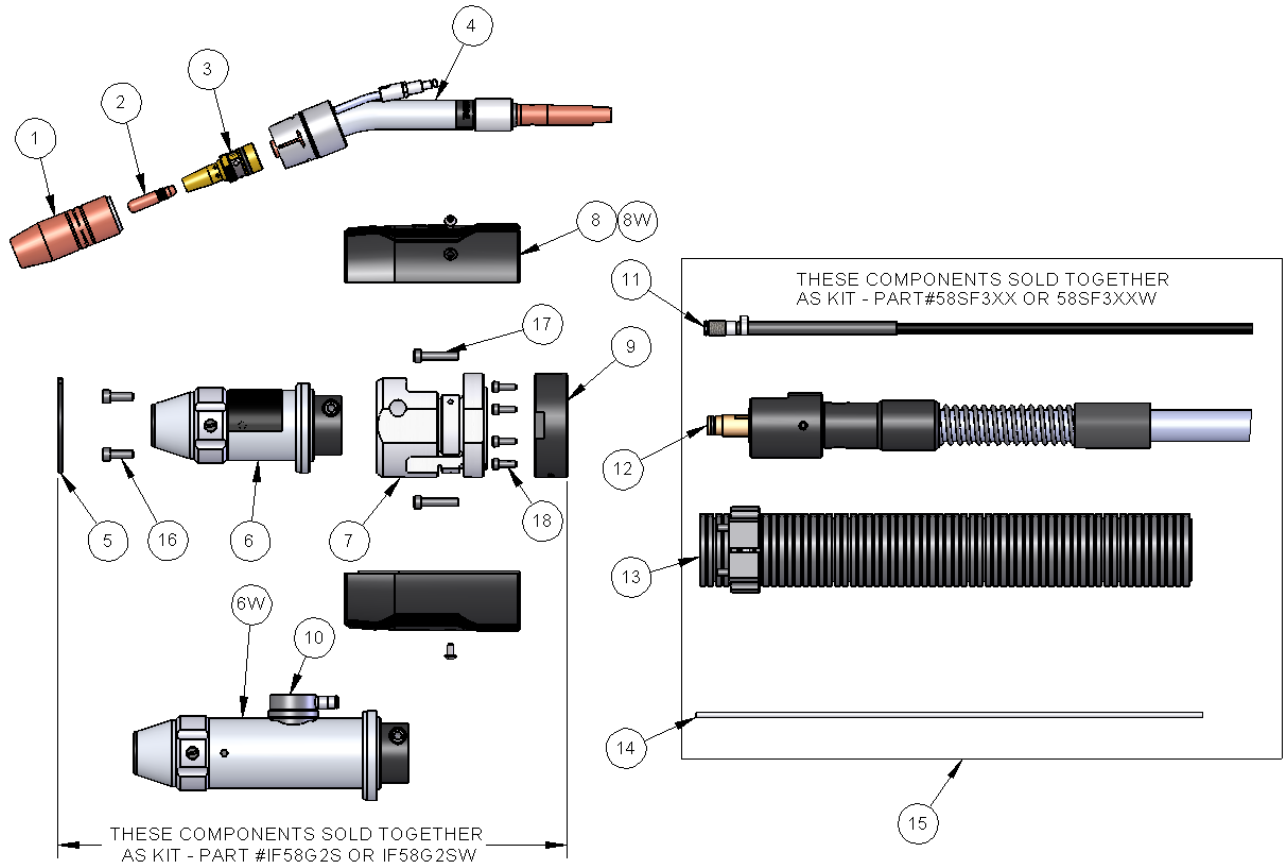

PART #	DESCRIPTION
1	401-X-XX NOZZLE
2	403-XX-XX TOUGH LOCK TIP
3	404-XX RETAINING HEAD
4	593-22-X TG ICE GOOSENECK 22 DEGREE
	593-22L-X TG ICE GOOSENECK MEDIUM LENGTH 22 DEGREE
	593-22L1-X TG ICE GOOSENECK LONGER LENGTH 22 DEGREE
	593-35-X TG ICE GOOSENECK 35 DEGREE
	593-45-X TG ICE GOOSENECK 45 DEGREE
	593-45L-X TG ICE GOOSENECK STANDARD 45 DEGREE
	593-45L1-X TG ICE GOOSENECK MEDIUM LENGTH 45 DEGREE
	593-45L2-X TG ICE GOOSENECK LONGER LENGTH 45 DEGREE
5	560-501-12 RUBBER FASTENER COVER
6	580-400 THRUARM G2 CONNECTOR
6W	580-400W THRUARM G2 CONNECTOR WB
7	560-501-10 W/C SPACER ASSEMBLY
8	560-5-2 FANUC OUTER COVER W/C
8W	580-400-6 FANUC OUTER COVER WB
9	560-501-11 INSULATING DISC
10	599 WIRE BRAKE UNIT
11	580-401-2 WATER LINES

PART #	DESCRIPTION
12	58SF205-2 W/C LSR UNICABLE SUB-ASSY FOR 100iC
	58SF206-2 W/C LSR UNICABLE SUB-ASSY FOR 120iC
	58SF207-2 W/C LSR UNICABLE SUB-ASSY FOR 100iC-6L
	58SF208-2 W/C LSR UNICABLE SUB-ASSY FOR 120iC-10L
13	560-501-6A OUTER JACKET ASSEMBLY 100iC
	560-501-6B OUTER JACKET ASSEMBLY 120iC
	560-501-6C OUTER JACKET ASSEMBLY 100iC-6L
	560-501-6D OUTER JACKET ASSEMBLY 120iC-10L
14	499-9-10 WIRE BRAKE LINE
15	58SF305 W/C LSR UNICABLE FOR 100iC
	58SF306 W/C LSR UNICABLE FOR 120iC
	58SF307 W/C LSR UNICABLE FOR 100iC-6L
	58SF308 W/C LSR UNICABLE FOR 120iC-10L
	58SF305W W/C LSR UNICABLE FOR 100iC (WB)
	58SF306W W/C LSR UNICABLE FOR 120iC (WB)
	58SF307W W/C LSR UNICABLE FOR 100iC-6L (WB)
	58SF308W W/C LSR UNICABLE FOR 120iC-10L (WB)
16	M5X.8X16mm LG SHCS
17	M5X.8X25mm LG SHCS
18	M4X.7X12mm LG SHCS

7.0 – ORDERING INFORMATION

To order replacement parts for your TOUGH GUN ThruArm G2 Series Robotic MIG Gun, please contact your authorized Tregaskiss distributor.

For help with configuring a part number for a new TOUGH GUN ThruArm G2 Series Robotic MIG Gun, Tregaskiss Customer Service is available from Monday to Friday from 8:00 AM to 5:00 PM EST and can assist you via phone at 1-877-737-3111 (from Canada and USA) or +1-519-737-3000 (international).



For Technical Support:

Canada & U.S.A. Phone: 1-877-737-3111

International Phone: +1-519-737-3000

Email: techservices@tregaskiss.com

www.tregaskiss.com

Distributed by:

08/11 REV A

M084