



February 2008

### Summary

- Unlike the most recent through-arm robots from Motoman (EA1400N/1900N and the SSA2000), the original ES1400 and EA1900 robots are unique.
- This document provides a summary as to why these robots are unique and includes installation instructions for the LSR Unicable.
- Spare parts and other information can be found in the M058 (LSR Systems Tech Guide for Motoman EA1400N, EA1900N, and SSA2000).
- **NOTE: TOUGH GUN I.C.E.™ System is NOT compatible with the Tregaskiss LSR System. Use the Motoman OEM uncable in these situations.**

### Motoman EA1400 and EA1900

- This through-arm model was the first one release by Motoman.
- Often times, this series is referred to as the “XRC” series (XRC is the model of the robot controller for these robots).
- These systems are unique and provide limitations that are not found on the newer systems.
- KEY POINT: the LSR Unicable for this series is unique and will NOT work for other Motoman models.

### Distinguishing Features of the EA1400 and EA1900

- The logo on the side of the robot reads “EA1400” or “EA1900”.
- There is an offset feeder at the rear of the robot.
- The casting of the robot features a bend near the upper arm.

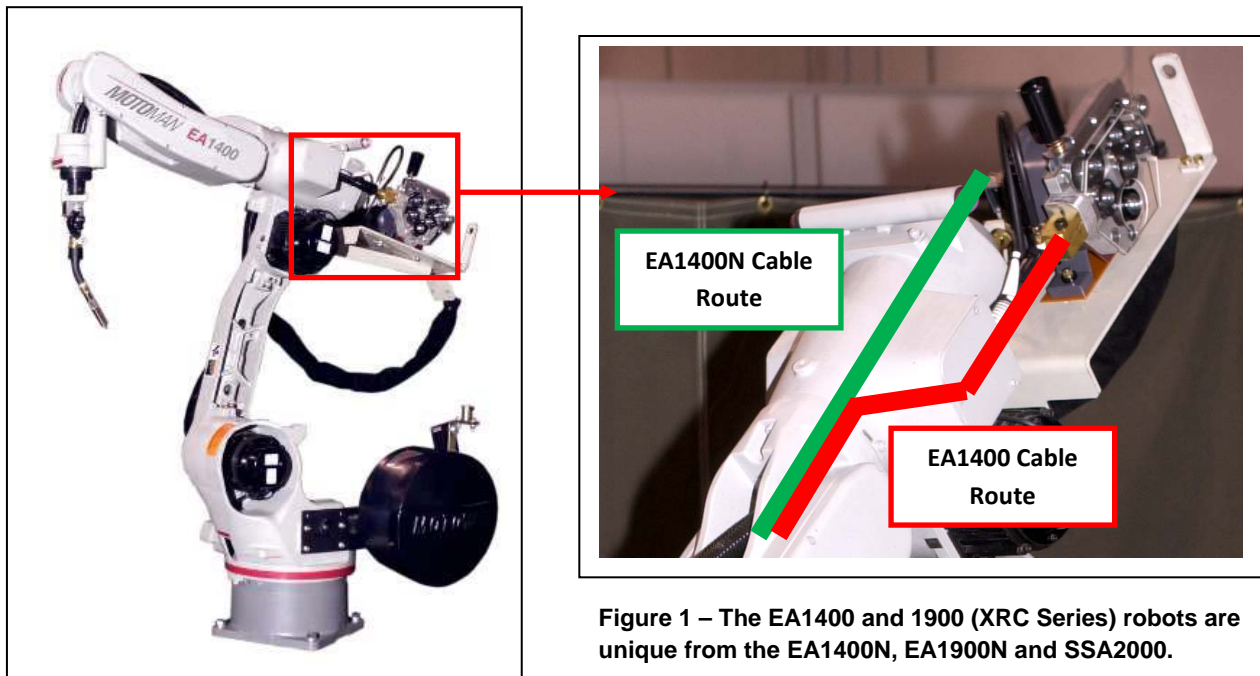

Figure 1 – The EA1400 and 1900 (XRC Series) robots are unique from the EA1400N, EA1900N and SSA2000.

## Installation Instructions for the LSR Unicable

- These instructions are based on the assumption that the 5800 Clutch System (below) is already installed on the faceplate of the robot.

### NOTE: Clutch System (5800) Components

**\*NOTE:** 2008 Model shown below with *NEW* outer cover. Older models have an all aluminum outer cover but the instructions for the LSR Unicable installation are applicable for this system as well.

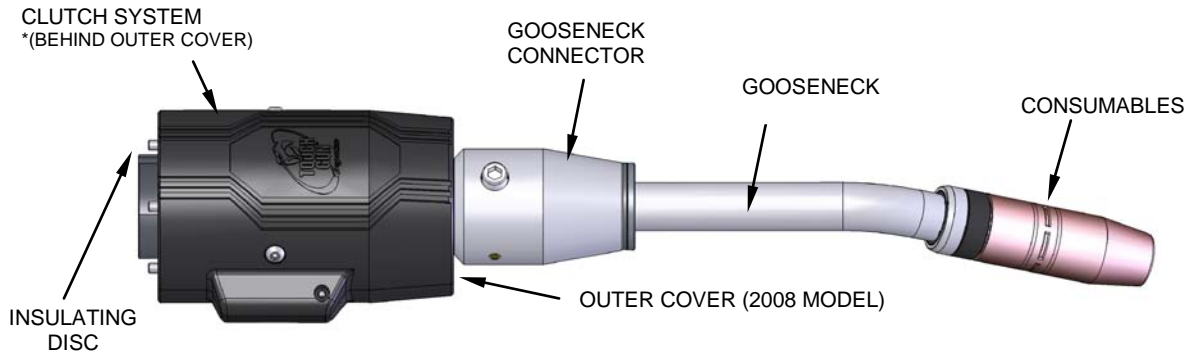

Figure 2 – The 5800 Clutch System is compatible with the Motoman EA1400, EA1900, EA1400N, EA1900N and the SSA2000. The most recent model is shown here with a black outer cover, rather than the original Aluminum design.

### STEP #1: Remove the Outer Cover of the 5800

**\*NOTE:** 2008 Model shown below with *NEW* outer cover. Older models have an aluminum outer cover but (other than step #1) the instructions for the LSR Unicable installation are applicable for this system as well.

- Unthread (3) M4 SBHCS, using 2.5 mm Allen key.
- Unthread (1) M3 SHCS, using 2.5 mm Allen key and pull apart both cover halves.
- Insulating disc should remain in place, located by dowel.

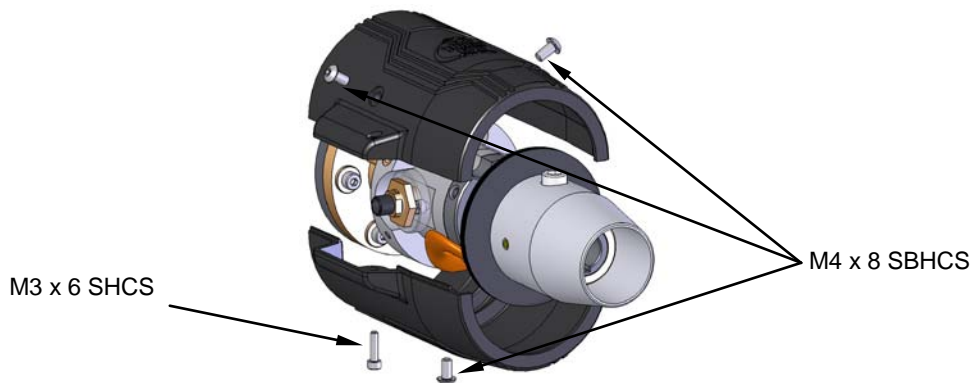

Figure 3 – The most recent 5800 features the black outer cover that splits into two pieces, using a total of 4 fasteners to hold it together.

## STEP #2: Install the LSR Unicable at the Front of the EA1400/1900

- Connect wire connectors (they are not polarity specific).
- Insert LSR Unicable Connector through mounting face of robot.
- Insert LSR Unicable Connector into flange-cable connector of the 5800.
- **NOTE:** Push the LSR Unicable down into the Flange Cable Connector and hold.
- While applying pressure to the LSR Unicable, secure the connector by tightening M6x20 SHCS, using 5 mm Allen key.

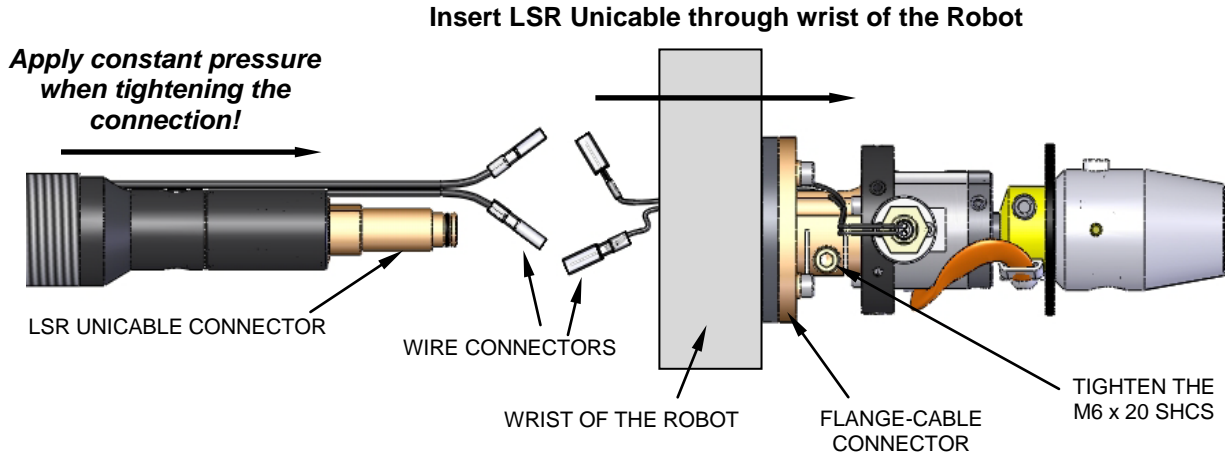

Figure 4 – When installing the LSR unicable to the 5800 Clutch System, be sure to maintain pressure towards to the 5800 when tightening the M6 screw to ensure a reliable connection.

## STEP #3: Re-Install the Outer Cover

- Reverse the directions of **STEP #1**.

## STEP #4: Install Gooseneck to the 5800

- STEP #4a: Insert new Gooseneck into connector housing until neck is fully seated.

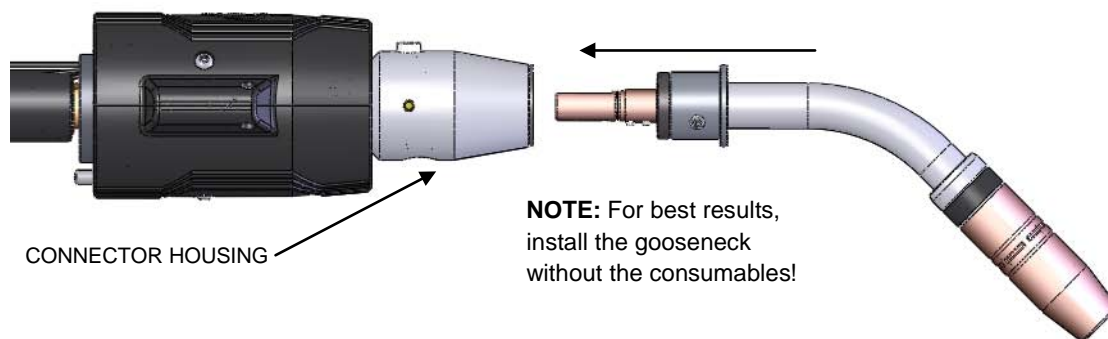

Figure 5 – For best results, remove the consumables from the gooseneck and re-install them during **STEP #9**. This technique will allow for the new QUICK LOAD Liner to be correctly installed.

- STEP #4b: Tighten Gooseneck bolt clockwise with 5 mm Allen key to torque specifications (60 in.-lbs. or 7 Nm).

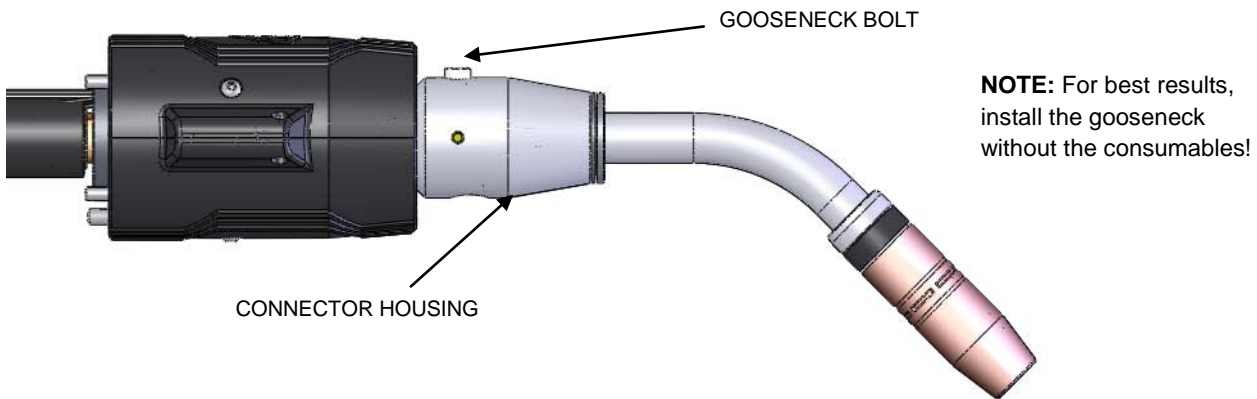

Figure 6 – When adding the gooseneck, apply just enough pressure to hold it in place as you tighten the gooseneck bolt to 60 in.-lbs. (7 Nm).

**STEP #5: Installation of LSR Unicable at the Rear of the EA1400/1900**

- Remove the cover on the side of the robot (Figure 7).

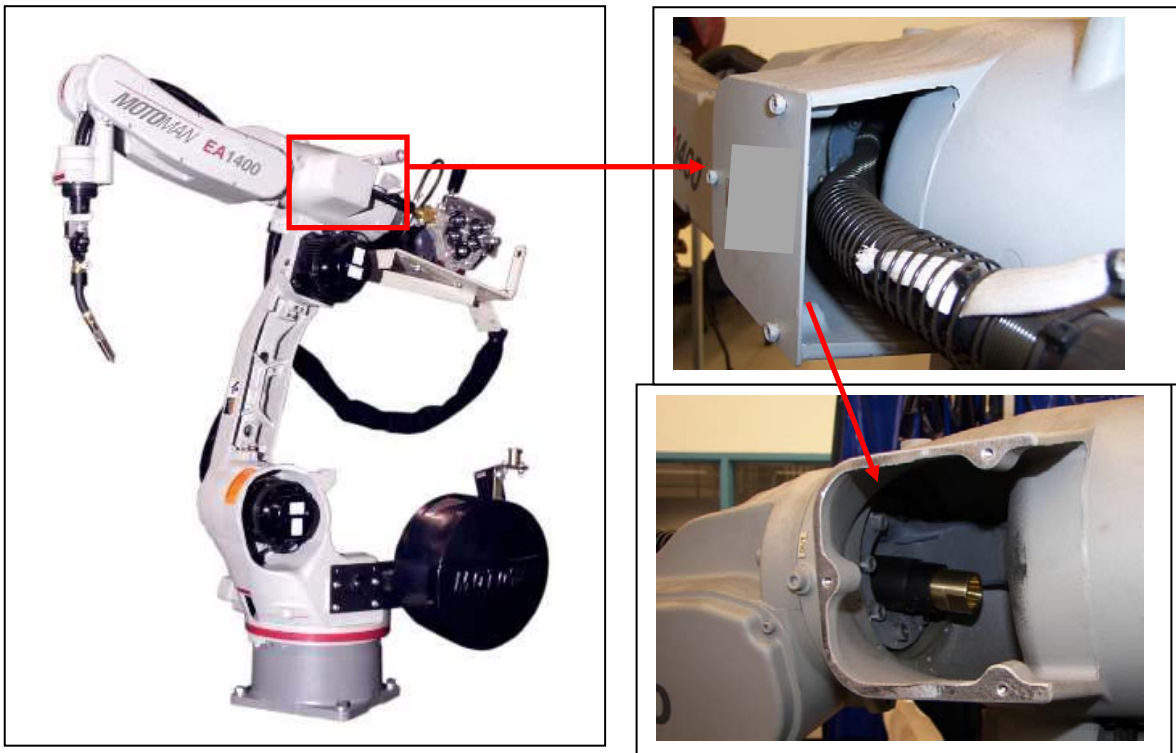
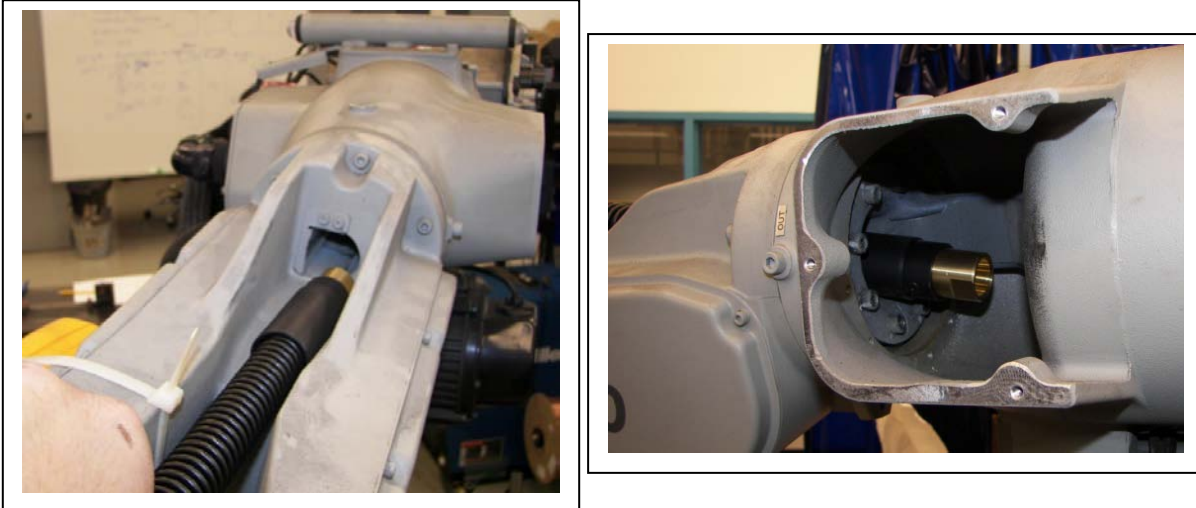

Figure 7 – On the side of the robot, remove the 3 screws holding the cover in place. Doing so provides access to the LSR Unicable as it is fished through the casting of the robot.

- Install the back-end of the LSR Unicable through the casting of the robot (Figure 8)
  - NOTE: The LSR Unicable must be installed through the casting of the robot WITHOUT the power pin or Euro connection. Otherwise, it will not fit through the casting



**Figure 8 – Insert the back-end of the LSR unicable through the hole in the casting of the upper arm.**

- Fish the cable through the robot using the access provided when the cover is removed

**STEP #6: Install Power Pin (or Euro connection)**

- Once the back-end of the LSR Unicable is pulled through the robot, add the power pin (or Euro connection to the LSR Unicable.
  - **NOTE:** Use wrenches to ensure the pin is secure and will not come loose. Adjustable wrenches are NOT recommended and they may strip the brass components!
- Tighten the power pin (or Euro connection) to the rear block using a 1" (25 mm) wrench on the rear block and a 5/8" (16 mm) or 3/4" (19 mm) wrench on the power pin



**Figure 9 – Once the LSR Unicable is pulled through the robot, add the power pin (or Euro connection).**

**NOTE: Make sure a wrench is used to provide a tight connection. Adjustable wrenches are NOT recommended!**

## STEP #7: Installation of the QUICK LOAD™ Liner (first installation only)

**NOTE:** The Initial installation of the QUICK LOAD Liner (QLL) is from the rear of the LSR Unicable (just like a conventional liner); however, subsequent liner replacements will be completed at the front of the LSR System.

- Add the QUICK LOAD Liner Retainer (Part #415-26) to the back of the QUICK LOAD Liner.
- From the rear of the LSR Unicable, feed replacement liner through the uncable using short strokes to avoid kinking.
- Secure the liner retainer in place with either the thread, or the power pin cap.
- If power pin is thread-in type:
  - Using a 10 mm wrench, turn thread-in liner retainer in a clockwise direction and tighten in power pin.
- At the front of the gooseneck, trim the liner (See Figure 10).
- Push liner back into front of gun and hold in place.
- Trim conduit to a 5/8" (16 mm) stick out.
- Remove any burr that may obstruct wire feed.

**Figure 10 – The recommended cut length for the QLL is 5/8" (16mm). Make sure the liner is pushed into the gooseneck when this length is determined.**

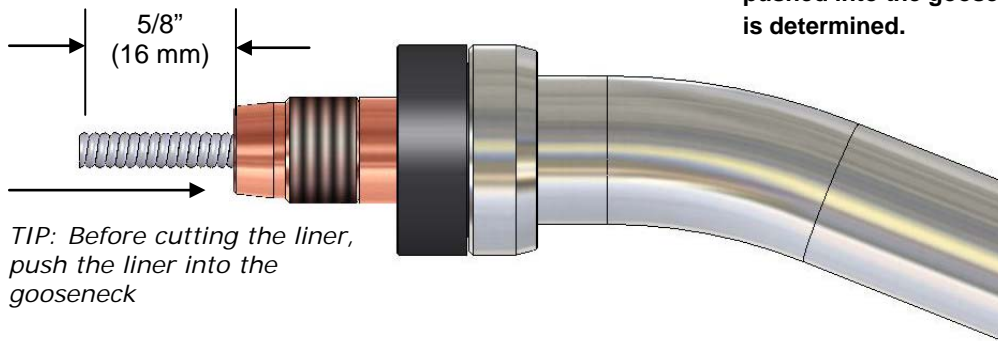

## STEP #8: Installing LSR Unicable into the Wire Feeder

- Install the control cable.
  - Connect the jumper control cable to the main control cable of the LSR Unicable.
  - Connect to the wire feeder as per the manufacturer's instructions.
- Install into wire feeder as per the manufacturer's instructions.



**Figure 11 – Install the power pin or Euro connection to the wire feeder, as per the manufacturer's instructions. The wire feeder control cable is also added during this step.**

## STEP #9: Install Consumables to the Gooseneck

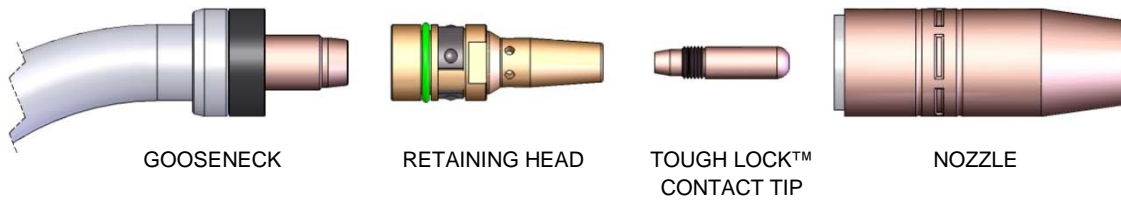

Figure 12– Install the consumables to the gooseneck using the instructions listed below.

### IMPORTANT

- Be sure all parts are tightened well before welding to prevent overheating of contact tip.
- Torque specs - Retaining Head 80 in.-lbs. / Contact Tip 30 in.-lbs.
- When installing the retaining head make sure it is tightened with a 5/8" (16 mm) wrench.
- To prevent scoring on retaining head do not use pliers.

### Removal and Replacement

- Pull slip-on nozzles off with a clockwise twisting motion.
- When installing nozzle, exposed insulator should nest inside TOUGH GUN I.C.E.™ insulator to assure concentricity.
- Replace retaining head with large bore toward the gooseneck. Tighten until retainer is secure.
- External gooseneck thread can be cleaned with a 9/16" - 18 die.

## STEP #10: Replace the Cover on the Robot

- Reverse the instructions from step #5 and re-install the cover to the robot



Figure 13 – To complete the installation, return the cover that was removed in STEP #5.

## MAINTENANCE/SPARE PARTS/PARTS BREAKDOWN

- Refer to the following Tech Guide for this information:
  - Low-Stress Robotic (LSR) System for MOTOMAN EA1400N, EA 1900N and SSA2000 Robots.
  - Part Number: M058.

